

Transfer Pump CSH



★ **DISTRIBUTION**
CRYOSTAR

Technical Index

★ Pump ID Meaning

CSH 260 or 185 / 5 or 4
(model) (impeller Ø in mm) (impeller tip width in mm)

Applications	Road tankers
Liquids pumped	LO ₂ , LN ₂ , LAr, LCH ₄
Drive type	Hydraulic (Hytran system)
Hydraulic motor power	Up to 70 kW
Design pressure	Up to 50 bar

★ Test Procedure

Each pump manufactured by CRYOSTAR is mechanically and cryogenically tested prior to shipment in our state-of-the-art testing facility to ensure that performance meets customer specification. The precision of measuring devices provides essential results : differential head, flow rate, seal gas consumption, pump efficiency, NPSH, noise and vibration levels – all documented and submitted to the customer.

★ Quality

Designed in compliance with guidelines like IGC 11/82 norm

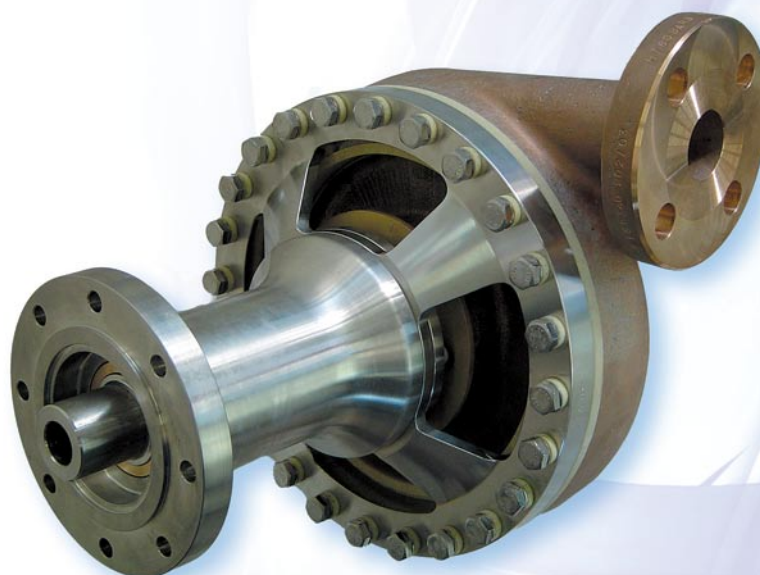

★ Performance

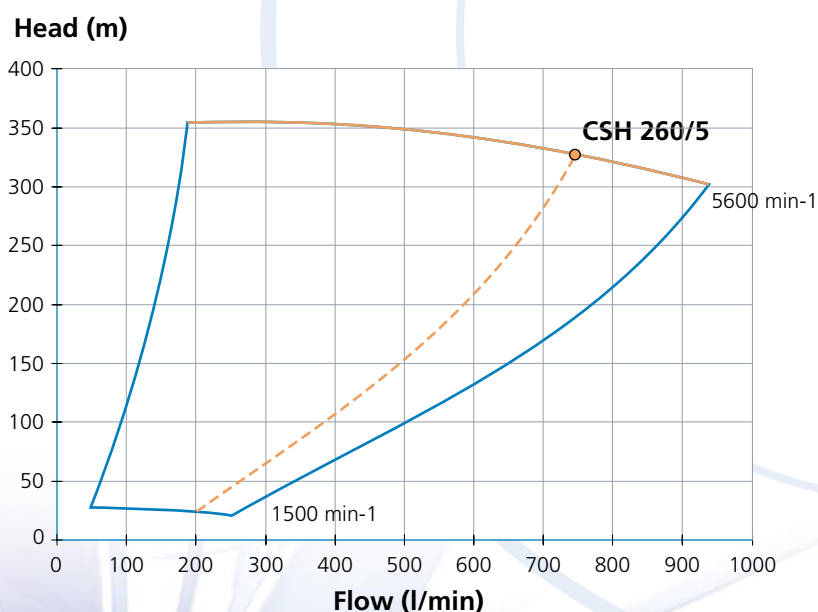

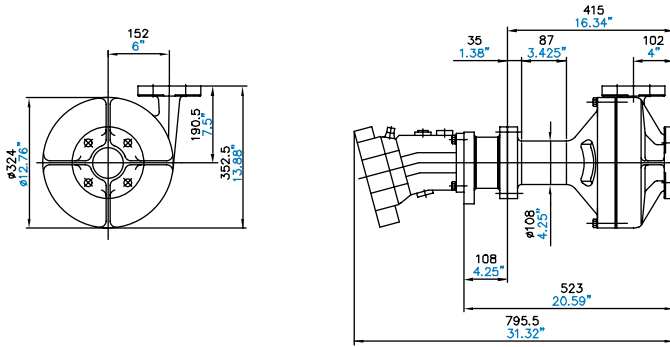

Possible arrangements

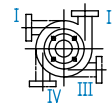

Dimensions in mm
Dimensions in inch

Weight without hydraulic motor
m: 165 pound / 75Kg

★ Features

- ★ The hydraulic pump is driven by the truck's power take-off via the truck gearbox which includes an electric piloted flow control valve to allow adjustment of the cryogenic pump speed
- ★ Hydraulic couplings are supplied with fast couplers in order to easily disconnect the vehicle tractor
- ★ The hydraulic circuit is protected by a safety valve installed on the hydraulic pump in order to prevent overloading of the Hytran system
- ★ Control system: a manometer is installed on the high pressure hydraulic circuit to monitor the pressure of the complete hydraulic system.
- ★ At constant speed, the cryogenic pump flow can be adjusted via the discharge line valve
The pump is protected by a non return valve, installed on a parallel circuit in order to prevent a suddenly flow shutdown

- 1 The pump shaft is mechanically sealed with a Cryostar composite faced seal, capable of providing up to 4 times the wearing life of conventional carbon faced mechanical seal.
- 2 Closed impeller with axial suction and radial discharge. Impeller balance is achieved hydraulically to minimize the axial load on the bearings
- 3 Bronze helical inducer results in low NPSH requirements with hydraulic optimal conception.

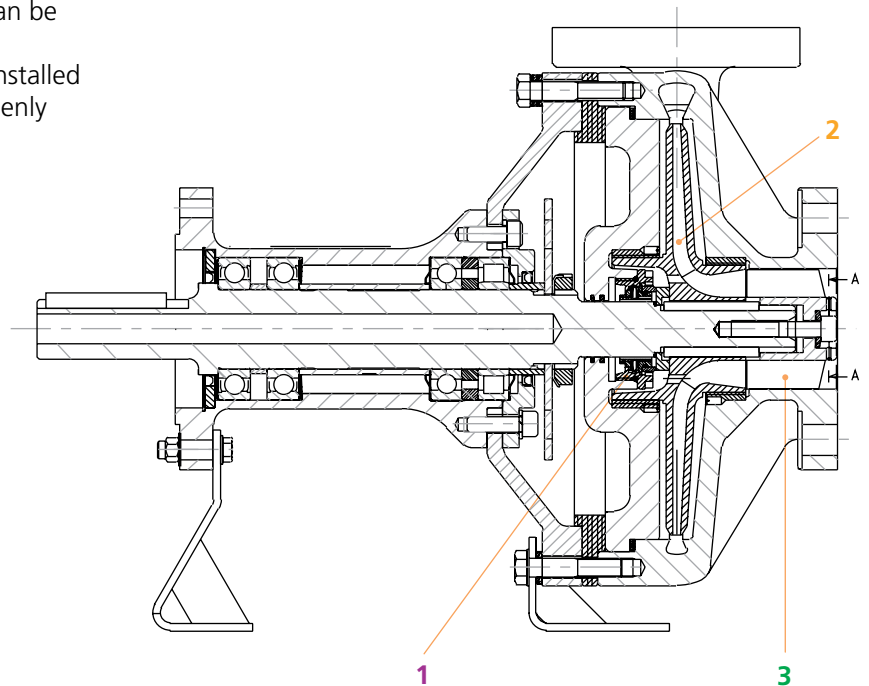

★ Options

- ★ Differential pressure switch (protection against dry running)
- ★ Cool down temperature probe
- ★ Leak detection temperature probe
- ★ Purged seal
- ★ Complete skid mounted assembly

For more details please contact your local Cryostar representative



CRYOSTAR Automation	tel : +33 (0) 5 65 80 20 20	info@cryostar.com
CRYOSTAR Brazil	tel : +55 11 5092 5262	brazil@cryostar.com
CRYOSTAR China	tel : +86 571 8536 8331	china@cryostar.com
CRYOSTAR France	tel : +33 (0) 3 89 70 27 27	info@cryostar.com
CRYOSTAR Singapore	tel : +65 6276 7441	singapore@cryostar.com
CRYOSTAR UK	tel : +44 1709 702 777	uk@cryostar.com
CRYOSTAR USA East	tel : 1-800-483-1052	usa@cryostar.com
CRYOSTAR USA West	tel : +1 (562) 903-1290	usa@cryostar.com
CRYOSTAR USA - Houston Office	tel : +1 (713) 661-6000	usa.houston@cryostar.com



www.cryostar.com