



Transfer Pump CO 120



★ **DISTRIBUTION**
CRYOSTAR

Technical Index

★ Pump ID Meaning

CO (model)	120 (Impeller Ø in mm)
Applications	Filling of small capacity low and high pressure tanks (mini-bulk deliveries etc...) Road tankers
Liquids pumped	LOX, LIN, LAr, LCO ₂ , LN ₂ O, LNG
Drive type	Direct coupled
Design pressure	Up to 36 bars / 525 PSI



★ Test Procedure

Each pump manufactured by CRYOSTAR is mechanically and cryogenically tested prior to shipment in our state-of-the-art testing facility to ensure that performance meets customer specification. The precision of measuring devices provides essential results : differential head, flow rate, seal gas consumption, pump efficiency, NPSH, noise and vibration levels – all documented and submitted to the customer.

★ Quality

Designed in compliance with guidelines like IGC 11/82 norm

★ Performance

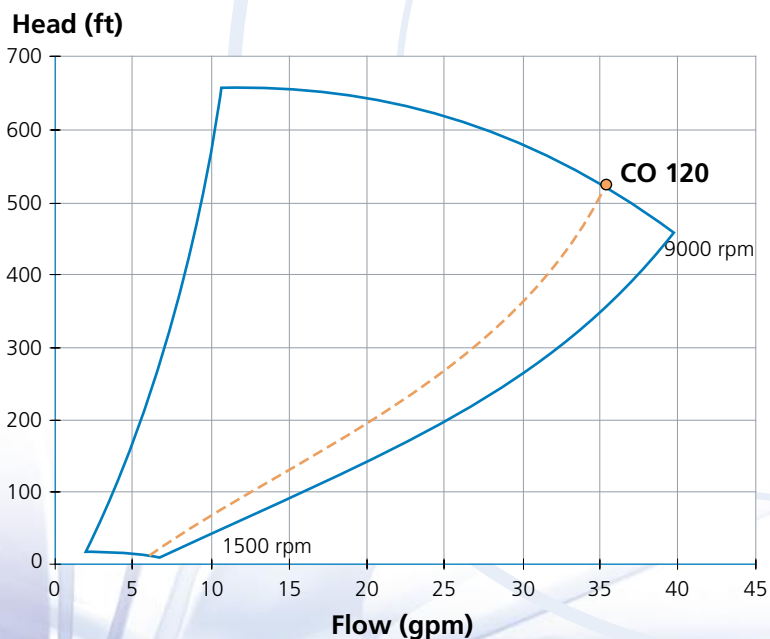



- 1 CRYOSTAR composite mechanical seal (4 times longer life time than carbon seals)
 - for LCO₂ application : special CRYOSTAR high pressure mechanical seal
 - for long life application : CRYOSTAR gas seal
- 2 Front opening of housing: for an easier maintenance
- 3 Designed to give a reliable and safe operation in all circumstances, particularly for oxygen operations
- 4 Reduced dimensions/weight
- 5 Pump speed can be adjusted through the variable speed motor (driven by a Variable Frequency Drive)
6. Helical inducer allowing low required NPSH

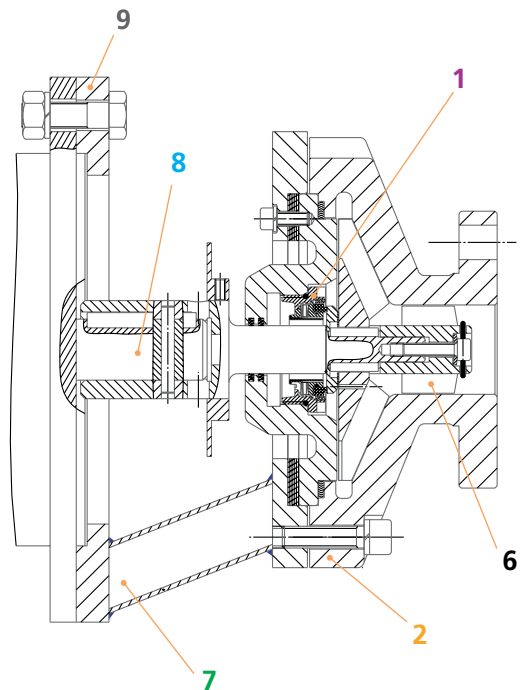
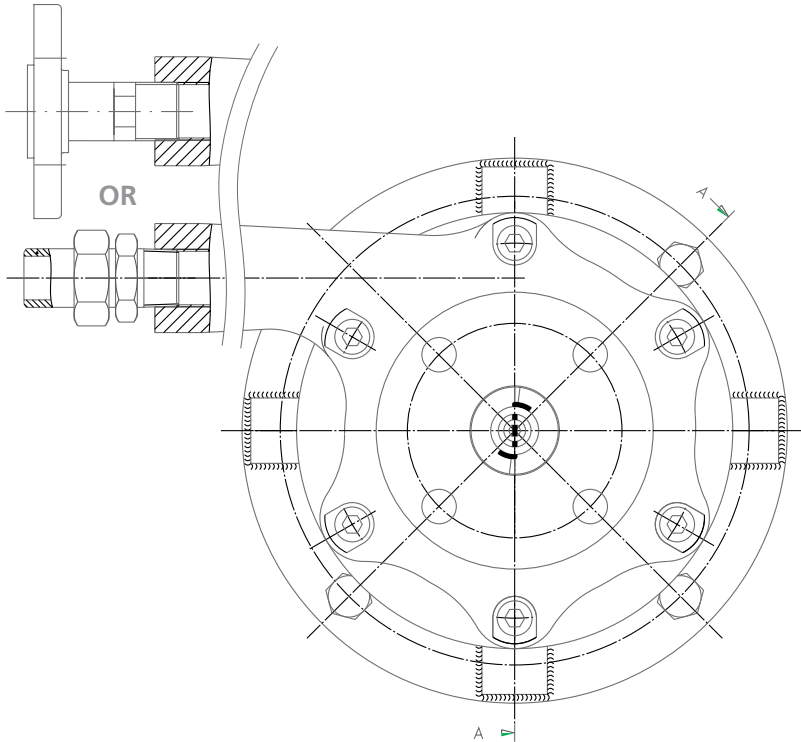

Permacold barrier consisting of:

- 7 Volute separated from the electrical motor by an open intermediate piece with 4 hollow arms. This intermediate piece only presents 4 contacts points for low thermal conductivity.
- 8 Hollow shaft reducing the thermal conductivity to minimum.
- 9 Thick insulation plate providing low thermal conductivity

For more details please contact your local Cryostar representative



CRYOSTAR Automation	tel : +33 (0) 5 65 80 20 20	info@cryostar.com
CRYOSTAR Brazil	tel : +55 11 5092 5262	brazil@cryostar.com
CRYOSTAR China	tel : +86 571 8536 8331	china@cryostar.com
CRYOSTAR France	tel: +33 (0) 3 89 70 27 27	info@cryostar.com
CRYOSTAR Singapore	tel : +65 6276 7441	singapore@cryostar.com
CRYOSTAR UK	tel : +44 1709 702 777	uk@cryostar.com
CRYOSTAR USA East	tel : 1-800-483-1052	usa@cryostar.com
CRYOSTAR USA West	tel : +1 (562) 903-1290	usa@cryostar.com
CRYOSTAR USA - Houston Office	tel : +1 (713) 661-6000	usa.houston@cryostar.com

