



# Transfer Pump GBS



★ **DISTRIBUTION**  
CRYOSTAR

## Technical Index

### ★ Pump ID Meaning

GBS      155      /      4.5  
(model)    (impeller Ø in mm)    (impeller tip width)

Applications	Stationary pump for liquid transfer
	Road tankers
Liquids pumped	LOX, LIN, LAr, LCO <sub>2</sub> , LN <sub>2</sub> O, LNG
Drive type	Gearbox
Design pressure	28 bar standard (406 psi)
	40 bar for CO <sub>2</sub> version (580 psi)



### ★ Test Procedure

Each pump manufactured by CRYOSTAR is mechanically and cryogenically tested prior to shipment in our state-of-the-art testing facility to ensure that performance meets customer specification. The precision of measuring devices provides essential results : differential head, flow rate, seal gas consumption, pump efficiency, NPSH, noise and vibration levels - all documented and submitted to the customer.

### ★ Quality

Designed in compliance with guidelines like IGC 11/82 norm

### ★ Performance

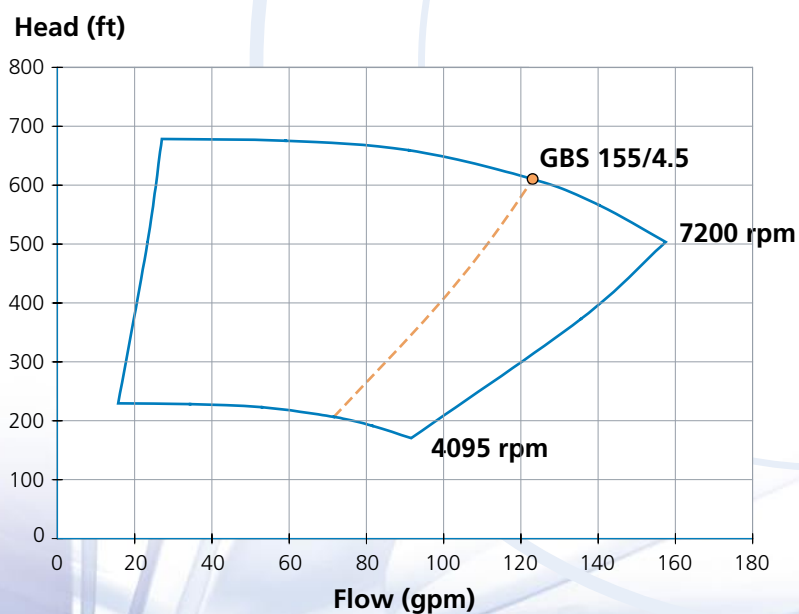

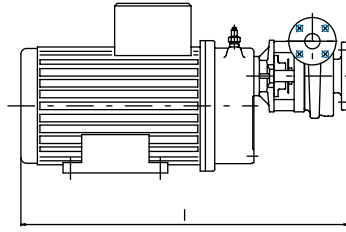
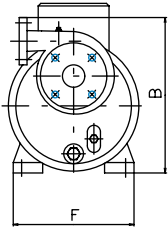

Possible arrangements

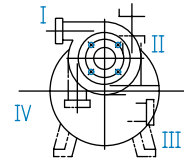

	KW		Motor frame	I	F	B
	50hZ	60hZ				
GBS 155/4.5	22	25	180	878.5	324	431.5

## ★ Features

- 1 Front opening of housing : easy and reliable replacement of mechanical seal without the need for readjustment of the run-out
- 2 CRYOSTAR composite mechanical seal (4 times longer life time than carbon seals)  
-> for CO2 application : special CRYOSTAR high pressure mechanical seal  
-> for a long life application : CRYOSTAR gas seal
- 3 High hydraulic efficiency closed impeller
- 4 Helical inducer allowing low required NPSH
- 5 Splash lubricated gearbox with oxygen compatible oil
- 6 Helicoidal gearwheels for low noise level

- 7 Pump support with 3 bearings :  
2 for radial thrust and 1 for radial and axial thrust

### Permacold barrier consisting of:

- 8 4 hollow arms open intermediate piece between the volute and the motor
- 9 Hollow shaft reducing thermal conductivity to a minimum
- 10 Thick insulation plate providing low thermal conductivity

## ★ Options

- ★ Differential pressure switch
- ★ Cool down temperature probe
- ★ Leak detection temperature probe
- ★ Purged seal
- ★ Purged gearbox
- ★ Complete skid mounted assembly

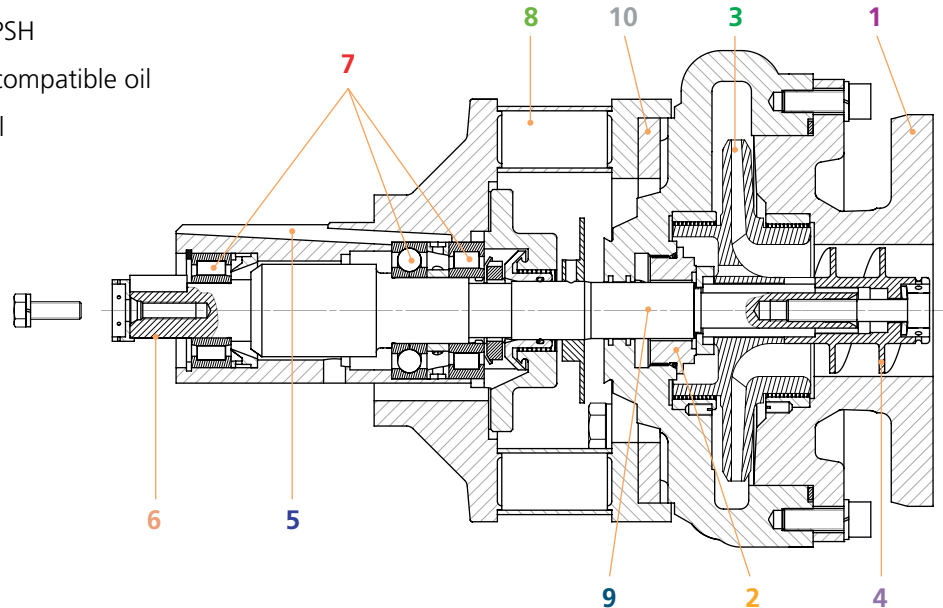

For more details please contact your local Cryostar representative



CRYOSTAR Automation	tel : +33 (0) 5 65 80 20 20	info@cryostar.com
CRYOSTAR Brazil	tel : +55 11 5092 5262	brazil@cryostar.com
CRYOSTAR China	tel : +86 571 8536 8331	china@cryostar.com
CRYOSTAR France	tel : +33 (0) 3 89 70 27 27	info@cryostar.com
CRYOSTAR Singapore	tel : +65 6276 7441	singapore@cryostar.com
CRYOSTAR UK	tel : +44 1709 702 777	uk@cryostar.com
CRYOSTAR USA East	tel : 1-800-483-1052	usa@cryostar.com
CRYOSTAR USA West	tel : +1 (562) 903-1290	usa@cryostar.com
CRYOSTAR USA - Houston Office	tel : +1 (713) 661-6000	usa.houston@cryostar.com



[www.cryostar.com](http://www.cryostar.com)