



Reciprocating Pump PPC

★ **DISTRIBUTION**
CRYOSTAR

Technical Index

★ Pump ID Meaning

PPC 35 or 45 / 26
(model) (piston Ø in mm) (piston stroke in mm)

Applications	Cylinder filling
Liquids pumped	LCO ₂ , LN ₂ O
Drive type	Grease lubricated crank drive
Design pressure (35/26)	120 bar / 1740 PSI
Design pressure (45/26)	100 bar / 1450 PSI

★ Test Procedure

Each pump manufactured by CRYO-STAR is mechanically and cryogenically tested prior to shipment in our state-of-the-art testing facility to ensure that performance meets customer specification. The precision of measuring devices provides essential results : differential head, flow rate, seal gas consumption, pump efficiency, NPSH, noise and vibration levels – all documented and submitted to the customer.

★ Quality

Designed in compliance with guidelines like IGC 11/82 norm



★ Performance

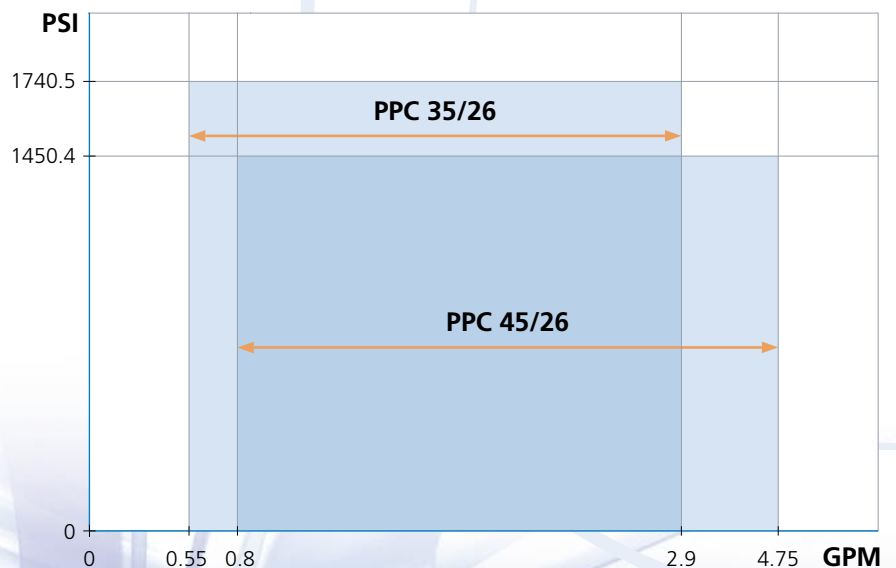

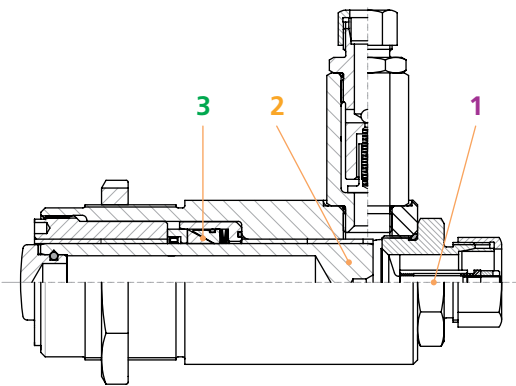
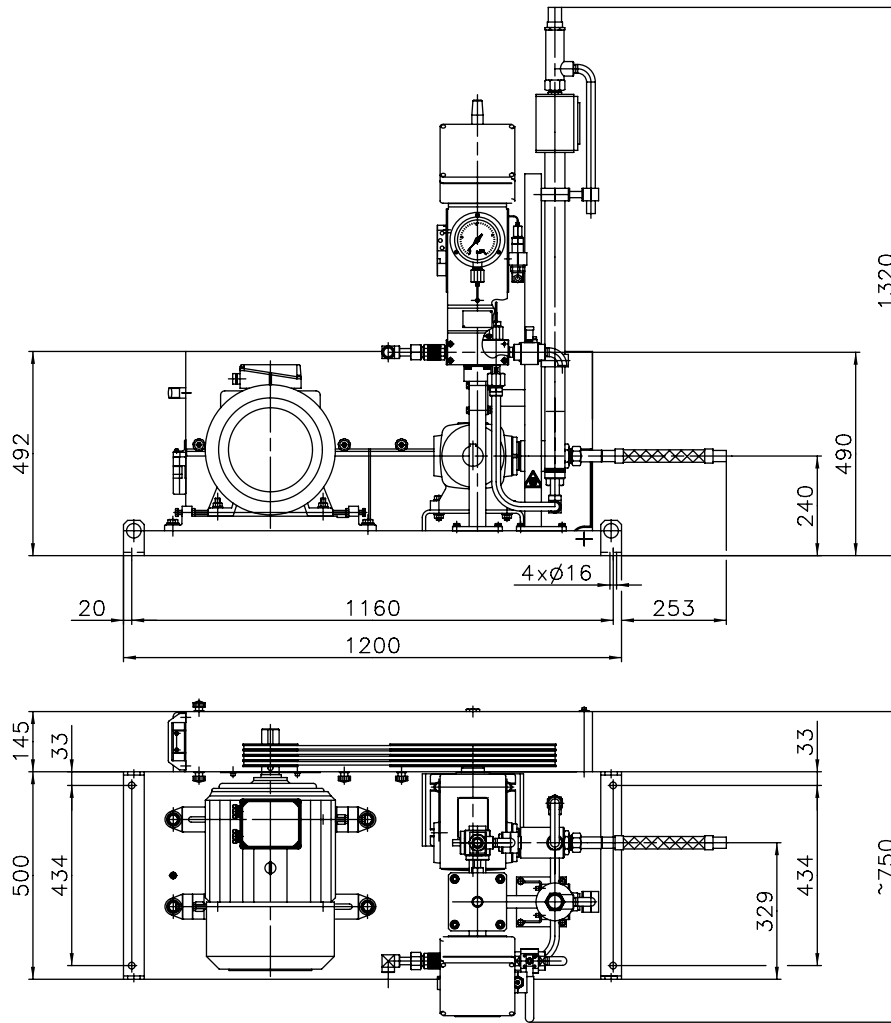

★ Features

- 1 The straight inflow suction valve provides the best possible low resistance flow characteristic, ensuring a low NPSH requirement. (large diameter of the inflow suction valve)
- 2 Piston made of stainless steel allowing a safer operation
- 3 Conical type sealing designed for CO₂/N₂O (higher suction pressure) applications

★ Options

- ★ Gas control unit

For more details please contact your local Cryostar representative



CRYOSTAR Automation	tel : +33 (0) 5 65 80 20 20	info@cryostar.com
CRYOSTAR Brazil	tel : +55 11 5092 5262	brazil@cryostar.com
CRYOSTAR China	tel : +86 571 8536 8331	china@cryostar.com
CRYOSTAR France	tel : +33 (0) 3 89 70 27 27	info@cryostar.com
CRYOSTAR Singapore	tel : +65 6276 7441	singapore@cryostar.com
CRYOSTAR UK	tel : +44 1709 702 777	uk@cryostar.com
CRYOSTAR USA East	tel : 1-800-483-1052	usa@cryostar.com
CRYOSTAR USA West	tel : +1 (562) 903-1290	usa@cryostar.com
CRYOSTAR USA - Houston Office	tel : +1 (713) 661-6000	usa.houston@cryostar.com



www.cryostar.com