



MIXTRAN

Trailer Unloading System



★ **DISTRIBUTION**
CRYOSTAR

Technical Index

★ Consists of

- ★ Cryogenic Pump (GBS 155/4.5, CBS 185/3 or CBS 2/155/4.5)
- ★ Pump control panel
- ★ Power cable with alternator socket
- ★ Generator control panel
- ★ Generator (50 Hz, 40 KVA or 60 Hz, 48 KVA)

Applications	Road tankers
Liquids pumped	LOX, LIN, LAr, LCO ₂ , LN ₂ O, LNG
Power type	Truck engine or auxiliary supply
Speed	Single or dual

★ Test Procedure

Each MIXTRAN Centrifugal Pump System manufactured by CRYOSTAR is electrically, mechanically and cryogenically tested prior to shipment in our state-of-the-art testing facility to ensure that performance meets customer specification. The precision of measuring devices provides essential results : differential head, flow rate, seal gas consumption, pump efficiency, NPSH, noise and vibration levels – all documented and submitted to the customer.



1

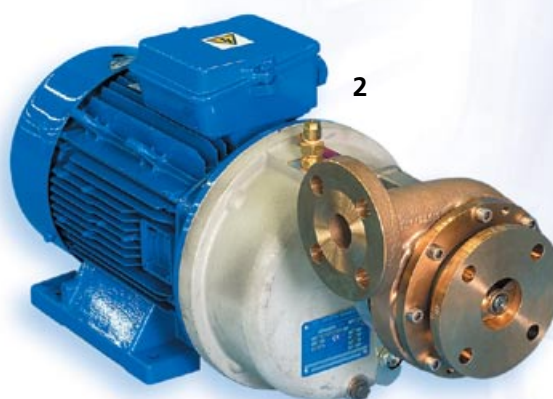

2

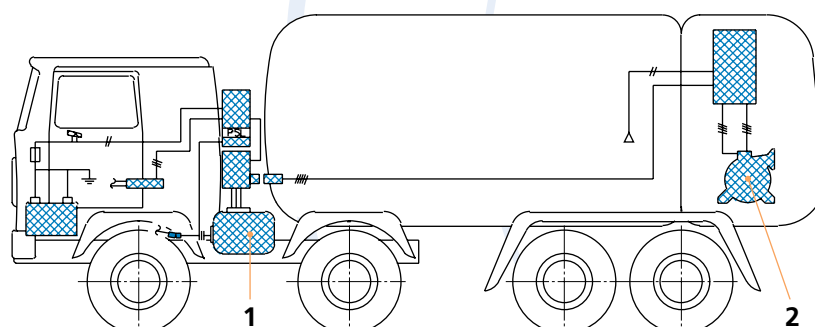

★ Quality

Designed in compliance with guidelines like IGC 11/82 norm

★ Performance

See corresponding pump data sheet



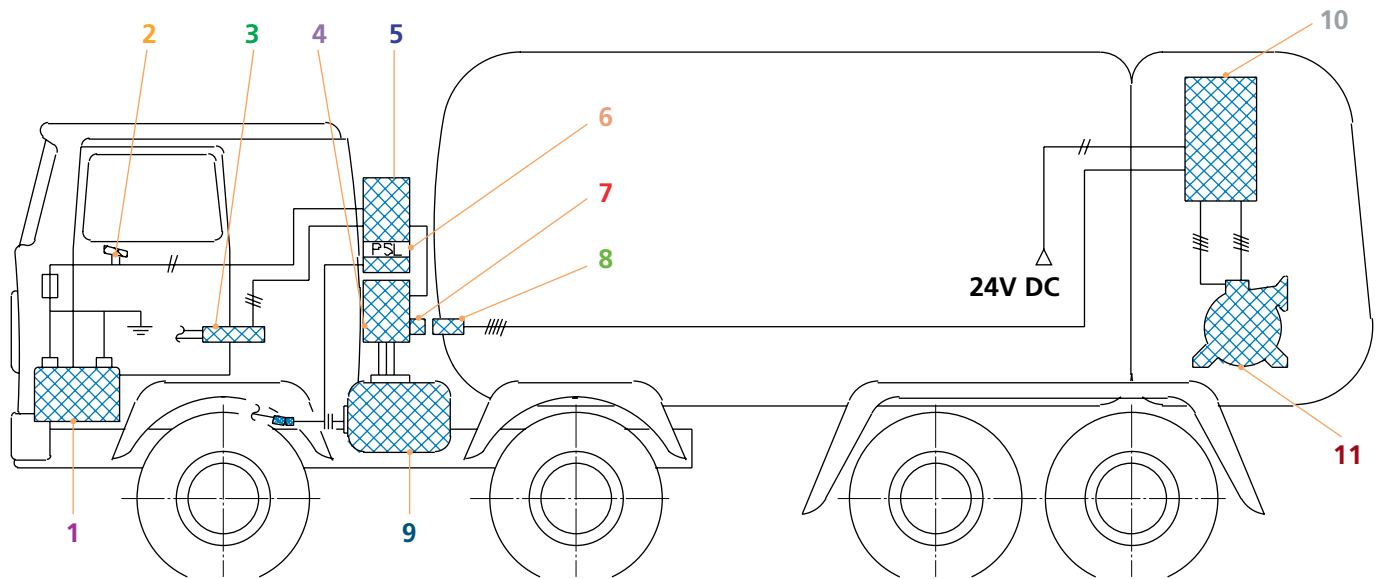

★ Scope of supply

- 1 Battery
- 2 Main switch
- 3 Motor actuator (not applicable for electronic injection)
- 4 Alternator junction box
- 5 Frequency control box
- 6 Pressure switch
- 7 Alternator socket
- 8 Power plug +cable 15m
- 9 Alternator (EME)
- 10 Pump motor control box
- 11 Cryogenic pump

★ Features

- ★ Compact pump with small overall dimensions
- ★ High efficiency
- ★ Front opening of housing : easy and reliable replacement of mechanical seal without the need for readjustment of the run-out
- ★ IP55 / NEMA4 control panel ready for installation that guarantees total safety as well as total interchangeability between different vehicles
- ★ Entire system specially protected against operational / environmental hazard

★ Options

- ★ Cool down safety and control
- ★ Pump anti cavitation system
- ★ Motor overheating protection
- ★ "Dead man's grip" button on the pump control panel

For more details please contact your local Cryostar representative



CRYOSTAR Automation	tel : +33 (0) 5 65 80 20 20	info@cryostar.com
CRYOSTAR Brazil	tel : +55 11 3709 5697	brazil@cryostar.com
CRYOSTAR China	tel : +86 571 8536 8331	china@cryostar.com
CRYOSTAR France	tel : +33 (0) 3 89 70 27 27	info@cryostar.com
CRYOSTAR Singapore	tel : +65 6276 7441	singapore@cryostar.com
CRYOSTAR UK	tel : +44 1709 702 777	uk@cryostar.com
CRYOSTAR USA East	tel : 1-800-483-1052	usa@cryostar.com
CRYOSTAR USA West	tel : +1 (562) 903-1290	usa@cryostar.com
CRYOSTAR USA - Houston Office	tel : +1 (713) 661-6000	usa.houston@cryostar.com

www.cryostar.com